

dbx[®]
by HARMAN

266xs

Dual Compressor/Gate



User Manual

Professional Audio Equipment

IMPORTANT SAFETY INFORMATION



CAUTION
RISK OF ELECTRIC SHOCK
DO NOT OPEN

ATTENTION: RISQUE DE CHOQUE ELECTRIQUE - NE PAS OUVRIR

WARNING: TO REDUCE THE RISK OF FIRE OR ELECTRIC SHOCK DO NOT EXPOSE THIS EQUIPMENT TO RAIN OR MOISTURE

The symbols shown above are internationally accepted symbols that warn of potential hazards with electrical products. The lightning flash with arrowpoint in an equilateral triangle means that there are dangerous voltages present within the unit. The exclamation point in an equilateral triangle indicates that it is necessary for the user to refer to the owner's manual.

These symbols warn that there are no user serviceable parts inside the unit. Do not open the unit. Do not attempt to service the unit yourself. Refer all servicing to qualified personnel. Opening the chassis for any reason will void the manufacturer's warranty. Do not get the unit wet. If liquid is spilled on the unit, shut it off immediately and take it to a dealer for service. Disconnect the unit during storms to prevent damage.

SAFETY INSTRUCTIONS

NOTICE FOR CUSTOMERS IF YOUR UNIT IS EQUIPPED WITH A POWER CORD.

WARNING: THIS APPLIANCE SHALL BE CONNECTED TO A MAINS SOCKET OUTLET WITH A PROTECTIVE EARTHING CONNECTION.

The cores in the mains lead are coloured in accordance with the following code:

GREEN and YELLOW - Earth BLUE - Neutral BROWN - Live

As colours of the cores in the mains lead of this appliance may not correspond with the coloured markings identifying the terminals in your plug, proceed as follows:

- The core which is coloured green and yellow must be connected to the terminal in the plug marked with the letter E, or with the earth symbol, or coloured green, or green and yellow.
- The core which is coloured blue must be connected to the terminal marked N or coloured black.
- The core which is coloured brown must be connected to the terminal marked L or coloured red.

This equipment may require the use of a different line cord, attachment plug, or both, depending on the available power source at installation. If the attachment plug needs to be changed, refer servicing to qualified service personnel who should refer to the table below. The green/yellow wire shall be connected directly to the units chassis.

CONDUCTOR		WIRE COLOR	
		Normal	Alt
L	LIVE	BROWN	BLACK
N	NEUTRAL	BLUE	WHITE
E	EARTH GND	GREEN/ YEL	GREEN

WARNING: If the ground is defeated, certain fault conditions in the unit or in the system to which it is connected can result in full line voltage between chassis and earth ground. Severe injury or death can then result if the chassis and earth ground are touched simultaneously.

WARNING FOR YOUR PROTECTION READ THE FOLLOWING:

KEEP THESE INSTRUCTIONS

HEED ALL WARNINGS

FOLLOW ALL INSTRUCTIONS

THE APPARATUS SHALL NOT BE EXPOSED TO DRIPPING OR SPLASHING LIQUID AND NO OBJECT FILLED WITH LIQUID, SUCH AS VASES, SHALL BE PLACED ON THE APPARATUS.

CLEAN ONLY WITH A DRY CLOTH.

DO NOT BLOCK ANY OF THE VENTILATION OPENINGS. INSTALL IN ACCORDANCE WITH THE MANUFACTURER'S INSTRUCTIONS.

DO NOT INSTALL NEAR ANY HEAT SOURCES SUCH AS RADIATORS, HEAT REGISTERS, STOVES, OR OTHER APPARATUS (INCLUDING AMPLIFIERS) THAT PRODUCE HEAT.

ONLY USE ATTACHMENTS/ACCESSORIES SPECIFIED BY THE MANUFACTURER.

UNPLUG THIS APPARATUS DURING LIGHTNING STORMS OR WHEN UNUSED FOR LONG PERIODS OF TIME.

Do not defeat the safety purpose of the polarized or grounding-type plug. A polarized plug has two blades with one wider than the other. A grounding type plug has two blades and a third grounding prong. The wide blade or third prong are provided for your safety. If the provided plug does not fit your outlet, consult an electrician for replacement of the obsolete outlet.

Protect the power cord from being walked on or pinched particularly at plugs, convenience receptacles, and the point where they exit from the apparatus.

Use only with the cart stand, tripod bracket, or table specified by the manufacturer, or sold with the apparatus. When a cart is used, use caution when moving the cart/apparatus combination to avoid injury from tip-over.



Refer all servicing to qualified service personnel. Servicing is required when the apparatus has been damaged in any way, such as power-supply cord or plug is damaged, liquid has been spilled or objects have fallen into the apparatus, the apparatus has been exposed to rain or moisture, does not operate normally, or has been dropped.

POWER ON/OFF SWITCH: If the equipment has a Power switch, the Power switch used in this piece of equipment DOES NOT break the connection from the mains.

MAINS DISCONNECT: The plug shall remain readily operable. For rack-mount or installation where plug is not accessible, an all-pole mains switch with a contact separation of at least 3 mm in each pole shall be incorporated into the electrical installation of the rack or building.

FOR UNITS EQUIPPED WITH EXTERNALLY ACCESSIBLE FUSE RECEPTACLE: Replace fuse with same type and rating only.

MULTIPLE-INPUT VOLTAGE: This equipment may require the use of a different line cord, attachment plug, or both, depending on the available power source at installation. Connect this equipment only to the power source indicated on the equipment rear panel. To reduce the risk of fire or electric shock, refer servicing to qualified service personnel or equivalent.

If connected to 240V supply, a suitable CSA/UL certified power cord shall be used for this supply.

IMPORTANT SAFETY INFORMATION

ELECTROMAGNETIC COMPATIBILITY

This unit conforms to the Product Specifications noted on the **Declaration of Conformity**. Operation is subject to the following two conditions:

- this device may not cause harmful interference, and
- this device must accept any interference received, including interference that may cause undesired operation.

Operation of this unit within significant electromagnetic fields should be avoided.

- use only shielded interconnecting cables.

U.K. MAINS PLUG WARNING

A molded mains plug that has been cut off from the cord is unsafe. Discard the mains plug at a suitable disposal facility.

NEVER UNDER ANY CIRCUMSTANCES SHOULD YOU INSERT A DAMAGED OR CUT MAINS PLUG INTO A 13 AMP POWER SOCKET.

Do not use the mains plug without the fuse cover in place. Replacement fuse covers can be obtained from your local retailer. Replacement fuses are 13 amps and **MUST** be ASTA approved to BS1362.



If you want to dispose this product, do not mix it with general household waste. There is a separate collection system for used electronic products in accordance with legislation that requires proper treatment, recovery and recycling.

Private household in the 25 member states of the EU, in Switzerland and Norway may return their used electronic products free of charge to designated collection facilities or to a retailer (if you purchase a similar new one).

For Countries not mentioned above, please contact your local authorities for a correct method of disposal. By doing so you will ensure that your disposed product undergoes the necessary treatment, recovery and recycling and thus prevent potential negative effects on the environment and human health.

DECLARATION OF CONFORMITY

Manufacturer's Name: dbx Professional Products
Manufacturer's Address: 8760 S. Sandy Parkway
Sandy, Utah 84070, USA

declares that the product:

Product name: dbx 266xs
Note: Product name may be suffixed by the EU.

Product option: None

conforms to the following Product Specifications:

Safety: IEC 60065 -01+Amd 1

EMC: EN 55022:2006 (N/A; Analog Product)
IEC61000-4-2
IEC61000-4-3
IEC61000-4-4
IEC61000-4-5
IEC61000-4-6
IEC61000-4-8
IEC61000-4-11

Supplementary Information:

The product herewith complies with the requirements of the:
Low Voltage Directive 2006/95/EC
EMC Directive 2004/108/EC.
RoHS Directive 2002/95/EC
WEEE Directive 2002/96/EC

With regard to Directive 2005/32/EC and EC Regulation 1275/2008 of 17 December 2008, this product is designed, produced, and classified as Professional Audio Equipment and thus is exempt from this Directive.

Roger Johnsen
Vice President of Engineering
8760 S. Sandy Parkway
Sandy, Utah 84070, USA
Date: November 1, 2010

European Contact: Your local dbx Sales and Service Office or

Harman Music Group
8760 South Sandy Parkway
Sandy, Utah 84070, USA
Ph: (801) 566-8800
Fax: (801) 568-7583

Section 1- Introduction 1
1.1 Common Compressor Applications.... 1
1.2 Common Gating Applications..... 1
1.3 Service Contact Info..... 2
1.4 Warranty..... 3

Section 2- Getting Started 4
2.1 Rear Panel Connections 4
2.2 Front Panel Connections 5

Section 3 - Making Connections 8

Section 4 - Technical Support and Facts 9
4.1 Technical Support 9
4.2 Registration Card and User Feedback ... 9

Section A - Appendix..... 10
A.1 Technical Specifications..... 10
A.2 Block Diagram..... 11

Section 1 - Introduction

Congratulations on choosing the dbx 266xs Compressor/Gate. The 266xs provides traditional dbx sonic quality and performance for the working musician, DJ, studio operator or anyone who needs a friendly compressor/gate to achieve quality compression, gating and downward expansion quickly and easily. We recommend that you take a moment and read through the manual as it provides information that will assist you in using your unit to its fullest potential.

1.1 Common Compressor Applications

- Fattening a Kick Drum or Snare Drum
- Adding Sustain to Guitar or Synthesizer String Sounds
- Smoothing Out a Vocal Performance
- Raising a Signal Out of a Mix
- Preventing Sound System Overload
- Digital to Analog Transfers

The 266xs compressor is packed with just the right features to effectively reduce and control the dynamic range of your audio, add punch to flabby, loose sounds, or add sustain to instruments. The 266xs begins with the classic dbx compression made famous by our 160 line of compressors. Just set the 266xs Attack and Release controls to 12:00 to get the same response as those units. But there's more. We scaled the program-dependent Attack and Release controls with dbx's AutoDynamic™ circuitry, so that the 266xs full range of controls produce voicings that extend from slow leveling to aggressive peak limiting.

1.2 Common Gating Applications

- Gating Dry Percussive Sounds (e.g., Snare Drum, Kick Drum)
- Gating Sounds That Have Longer Decay (e.g., Cymbal, Piano)
- Gating Hum or Buzz From Live Instruments or Recorded Tracks
- Downward Expansion to Reduce Noise Under Smooth Sounds (e.g., Vocals, Woodwinds)

The 266xs gate is ready to tackle all your gating needs, whether you need to remove unwanted noise or other background sounds, tighten drum sounds, or change the characteristic envelope of an instrument. The 266xs gate provides more flexibility than traditional switch gates because it actually functions as a combination gate/expander. Where switch gates are generally only suitable for a limited number of uses (e.g., gating percussion), the gate on the 266xs acts as a gentle downward expander at low Ratio settings (suitable for vocals, guitar, mixed program, etc.), and can effectively work as a switch gate when used at high Ratio settings.

Refer to the following pages for suggested initial settings. These settings should suffice for traditional compressing and gating requirements. However, the 266xs can accomplish many more changes to sound quality. We recommend that you experiment with the 266xs controls; take our suggested settings and run with them, try totally different settings, and try unorthodox combinations of compressor and gating controls. You might be surprised at what you hear. Best of all, you may create the perfect sound quality for your needs.

1.3 Service Contact Info

If you require technical support, contact dbx Technical Support. Be prepared to accurately describe the problem. Know the serial number of your device - this is printed on a sticker attached to the chassis. If you have not already taken the time to fill out your warranty registration card and send it in, please do so now. You may also register online at www.dbxpro.com.

Before you return a product to the factory for service, we recommend you refer to the manual. Make sure you have correctly followed installation steps and operation procedures. For further technical assistance or service, please contact our Technical Support Department at (801) 568-7660 or visit www.dbxpro.com. If you need to return a product to the factory for service, you **MUST** first contact Technical Support to obtain a Return Authorization Number.

No returned products will be accepted at the factory without a Return Authorization Number.

Please refer to the Warranty information on the following page, which extends to the first end-user. After expiration of the warranty, a reasonable charge will be made for parts, labor, and packing if you choose to use the factory service facility. In all cases, you are responsible for transportation charges to the factory. dbx will pay return shipping if the unit is still under warranty.

Use the original packing material if it is available. Mark the package with the name of the shipper and with these words in red: DELICATE INSTRUMENT, FRAGILE! Also write the Return Authorization Number (RA#) on the outside of the box in a conspicuous location. Insure the package properly. Ship prepaid, not collect. Do not ship parcel post.

1.4 Warranty

This warranty is valid only for the original purchaser and only in the United States.

1. The warranty registration card that accompanies this product must be mailed within 30 days after purchase date to validate this warranty. You can also register online at www.dbxpro.com. Proof-of-purchase is considered to be the responsibility of the consumer. **A copy of the original purchase receipt must be provided for any warranty service.**
2. dbx warrants this product, when bought and used solely within the U.S., to be free from defects in materials and workmanship under normal use and service.
3. dbx liability under this warranty is limited to repairing or, at our discretion, replacing defective materials that show evidence of defect, provided the product is returned to dbx WITH RETURN AUTHORIZATION from the factory, where all parts and labor will be covered up to a period of two years. A Return Authorization number must first be obtained from dbx. The company shall not be liable for any consequential damage as a result of the product's use in any circuit or assembly.
4. dbx reserves the right to make changes in design or make additions to or improvements upon this product without incurring any obligation to install the same additions or improvements on products previously manufactured.
5. The foregoing is in lieu of all other warranties, expressed or implied, and dbx neither assumes nor authorizes any person to assume on its behalf any obligation or liability in connection with the sale of this product. In no event shall dbx or its dealers be liable for special or consequential damages or from any delay in the performance of this warranty due to causes beyond their control.

Section 2 - Getting Started

2.1 Rear Panel Connections

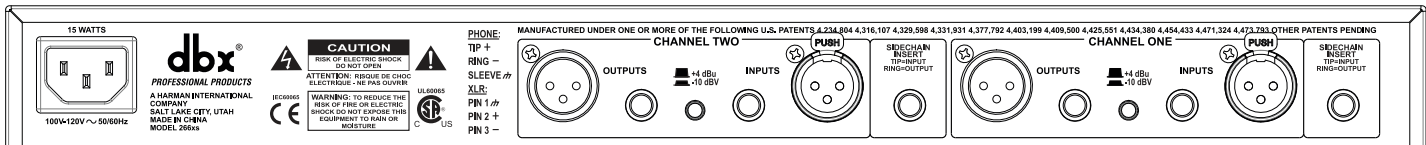

IEC Power Cord Receptacle

The dbx 266xs comes with a power supply that will accept voltages ranging from 100V-120V at frequencies from 50Hz-60Hz. An IEC cord is included. EU version accepts 220V-240V at frequencies from 50Hz-60Hz.



WARNING: Be sure to verify your actual line voltage is the same as the voltage level printed below the AC power receptacle. Connection to an inappropriate power source may result in extensive damage which is not covered by the warranty.



Caution: Never remove the cover. There are no user-serviceable parts inside.

INPUT Jacks (CHANNEL 1 and 2)

Use 1/4" TRS phone plugs or male XLR plugs to connect these inputs to your source. The 266xs INPUT jacks accept either balanced or unbalanced signals. Input impedance is >40kΩ.

OUTPUT Jacks (CHANNEL 1 and 2)

The OUTPUT jacks accept 1/4" TRS balanced or unbalanced phone plugs or female XLR plugs. Maximum output signal level is >+20dBu. In the +4dBu setting, the balanced output impedance is 100Ω, and the unbalanced output impedance is 50Ω. In the -10dBV setting, the balanced output impedance is 1kΩ and the unbalanced output impedance is 500Ω.

OPERATING LEVEL Switch

This switch selects between a -10dBV and +4dBu nominal operating level. When the switch is in the IN position, a -10dBV operating level is selected. When it is in the OUT position, a +4dBu operating level is selected.

SIDECHAIN INSERT Jack

This jack accepts 1/4" TRS phone plugs and provides a connection to the 266xs detector path. The RING acts as a Send, carrying a buffered version of the signal present at the 266xs INPUT jack, at an impedance of 2kΩ. The TIP acts as a Return for equipment to feed the 266xs detector circuitry, such as an equalizer for de-essing or frequency-sensitive gating/compression. You can also drive the 266xs Sidechain input with the output of most equipment, by using a 1/4" mono phone plug. Input Impedance is greater than 10kΩ.

NOTE: When a cable is plugged into this jack, it automatically breaks the connection from the INPUT jack to the 266xs detection circuitry.

2.2 Front Panel Connections

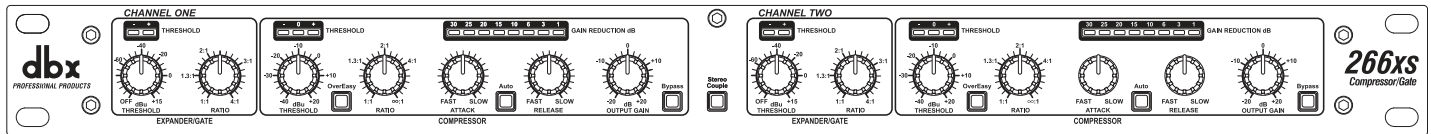

STEREO COUPLE Switch

This switch sets the 266xs for Stereo or Dual Mono operation. Press the STEREO COUPLE switch in for stereo operation where Channel 1 becomes the master controller for both channels. All of Channel 2's controls, switches, and LEDs will be disabled (except for the Channel 2 GAIN REDUCTION meter), since Channel 2 is the slave.

With the STEREO COUPLE switch out, the unit functions as two separate mono compressor/gates, each with its own independent controls.

The STEREO COUPLE switch lights red when the 266xs is stereo-coupled.

BYPASS Switch

Press this switch in to bypass the front panel controls, effectively canceling the function and processing effect of the 266xs compression, gating and gain settings. The input signal is still present at the 266xs Output, but is now unaltered by the 266xs controls. BYPASS is especially useful for making comparisons between processed and unprocessed signals. Note that with stereo operation (STEREO COUPLE switch pressed in), the Channel 1 BYPASS switch controls both channels.

The BYPASS switch lights red when BYPASS mode is active.

GAIN REDUCTION (dB) Meter

This meter displays the amount of signal attenuated from the input signal by the 266xs Compressor or Expander/Gate. When the Compressor and Expander/Gate are both active, the meter displays the maximum amount of gain reduction for whichever function is greater - Compressor or Expander/Gate.

OUTPUT GAIN (dB) Control

This control sets the overall gain of the 266xs, from -20dB to +20dB. The OUTPUT GAIN control is especially useful to compensate for the RMS level decrease which results from the 266xs dynamic processing effects. After you adjust the 266xs controls for the desired amount of compression, set the OUTPUT GAIN to add the same amount of gain that is shown on the GAIN REDUCTION meters. For example, if the average amount of gain reduction shown on the meters is 10dB, then setting the OUTPUT GAIN control to +10dB will compensate for the 10dB average level reduction at the output.

NOTE: The 266xs Compressor and Expander/Gate control settings are interactive and can affect gain, so watch your playback levels.

NOTE: Setting the Compressor RATIO to 1:1 will turn the Compressor off, regardless of the setting of the Compressor THRESHOLD control and BELOW/OVEREASY/ABOVE LED status. Setting the Compressor THRESHOLD control to +20dB will prevent all but the highest level peaks from being compressed.

OVEREASY® Switch

Depress this switch to select the OverEasy® compression characteristic. The amber THRESHOLD LED turns on when the signal is in the OverEasy region. When the switch is out, the 266xs operates as a hard-knee compressor, and the amber LED does not light.

Compressor THRESHOLD Control and LEDs (BELOW/OVEREASY/ABOVE)

Adjust this control to set the threshold of compression from - 40dB to +20dB. In hard-knee mode, the threshold of compression is defined as the point above which the output level no longer changes on a 1:1 basis with changes in the input level.

In OverEasy mode the threshold of compression is defined as the middle of the OverEasy threshold region, that is, “half-way” into compression.

The three THRESHOLD LEDs indicate the relationship of the input signal level to the threshold of compression. The green LED lights when the signal is BELOW threshold, the red LED lights when the signal is above threshold, and the yellow LED lights when the OVEREASY switch is depressed and the input signal is in the OVEREASY range.

The 266xs OverEasy compression permits extremely smooth, natural sounding compression, without artifacts, due to the gradual change of compression around the threshold. With OverEasy compression, input signals begin to gradually activate the 266xs internal gain change circuitry as they approach the THRESHOLD reference level. They do not get fully processed by the RATIO, ATTACK and RELEASE controls until they have passed somewhat above the THRESHOLD reference level. As the signal level passes the THRESHOLD level, processing increases until it is fully processed to the extent determined by the control settings.

In hard-knee mode, the 266xs can provide abrupt compression effects as well as hard-limiting applications. Note that when in hard knee mode the amber LED will not light as the input signal passes across the threshold. The signal is either being compressed (over threshold) or it is not being compressed (under threshold).

NOTE: Even though no input signal is being applied, it is normal for the LEDs to flicker on when the power is applied or removed.

Compressor RATIO Control

Adjust this control to set the amount of compression applied to the input signal. Clockwise rotation of this control increases the compression ratio from 1:1 (no compression) up to ∞ :1 (where the compressor can be considered to be a peak limiter, especially with faster ATTACK settings).

When an input is above the THRESHOLD setting reference level, the RATIO setting determines the number of decibels by which the input signal must increase in level to produce a 1dB increase in the signal level at the output of the 266xs. A setting of 2:1 indicates an input/output ratio wherein a 2dB increase in signal (above threshold) will produce a 1dB increase in output signal. A setting of ∞ :1 indicates that an infinite increase in input level would be required to raise the output level by 1dB.

Compressor ATTACK and RELEASE Control

The ATTACK control sets the amount of time it takes the 266xs to begin compressing a signal once the detector has sensed a signal above threshold. The ATTACK range is from FAST (for a tighter and more noticeable compression effect with very little overshoot) to SLOW (for more delayed, gradual compression). A very fast ATTACK setting will cause the 266xs to act like a peak limiter even though RMS detection circuitry is used. Slower ATTACK settings cause the 266xs to act like an RMS or averaging detecting compressor/limiter.

The RELEASE control sets how fast the compression circuit returns the input to its original level. The RELEASE rate is from FAST (where compression follows the envelope of the program material very tightly) to SLOW (for very smooth compression).

There is no absolute *right* way to set the ATTACK and RELEASE controls. However, in general, you will want them set slow enough to avoid pumping or breathing sounds caused when background sounds are audibly modulated by the dominant signal energy, yet the release must be fast enough to avoid suppression of the desired signal after a sudden transient or loud note has decayed. For low frequency tones (e.g., bass guitar), set RELEASE and ATTACK to 2:00 or slower.

NOTE: ATTACK and RELEASE controls operate together and in conjunction with the RATIO control. Changing one control may necessitate changing another setting.

AUTO Switch

This switch overrides both the ATTACK and RELEASE controls and enables preset program-dependent attack and release times. These times are derived from the input signal and continuously change to match its dynamics. Enabling this AUTO Function duplicates the “classic dbx sound” of the 266xs forerunners which have become standards in the industry.

Expander/Gate THRESHOLD Control and LEDs (BELOW/ABOVE)

NOTE: The Expander/Gate is off when the Expander/Gate THRESHOLD is set to OFF.

Adjusting this control sets the level at which the gate will open and allow the signal at the input to pass through to the output. Turning the knob fully counterclockwise (to OFF) allows the gate to pass all signals unattenuated, effectively bypassing the gate. Turning the knob fully clockwise causes the gate to attenuate input signals below +15dBu. The depth of attenuation depends on the setting of the Expander/Gate RATIO control.

The two Expander/Gate LEDs indicate the relationship of the input signal level to the threshold setting. The red LED lights when the signal is BELOW threshold, the green LED lights when the signal is ABOVE threshold.

Expander/Gate RATIO Control

This control sets the amount of attenuation applied to the input signal once it is below the threshold, from gentle downward expansion (appropriate for mixed program, vocals, etc.), to a hard gating effect (which can be useful for percussion). Fairly low RATIO (and higher Expander/Gate THRESHOLD) settings work best for downward expansion, whereas higher RATIO settings (clockwise towards MAX) work best for gating. If a setting produces undesirable pumping, readjust the Expander/Gate RATIO or THRESHOLD setting.

NOTE: The attack and release rate of the Expander/Gate are program-dependent - very fast for transient material (e.g., percussion) and slower for material with slow attack (e.g., vocals).

NOTE: Fast gating of sustained low frequency signals can result in “chattering”. To eliminate any “chattering” simply adjust the RATIO control. The proper THRESHOLD setting will also minimize false triggering and “chattering.”

Section 3 - Making Connections

The 266xs can be used with any line-level device. Some common examples include mixing consoles, electronic musical instruments, patch bays, and signal processors. For all connections, refer to the following steps:

Turn Off all equipment before making any connections.

Mount the 266xs in a 1U rack space (optional).

The 266xs requires one rack space (height) and 1 rack space (width). It can be mounted above or below anything that doesn't generate excessive heat, since it requires no special ventilation. Ambient temperatures should not exceed 113°F (45°C) when equipment is powered.

Make connections via 1/4" TRS phone or XLR jacks according to your requirements. Typical patch points include: a mixer's channel or subgroup inserts when using the 266xs on individual instruments or tracks; the mixer's main outputs when mixing; an instrument preamp's effects loop when using the 266xs for guitar or bass; main outs of a submixer (i.e., keyboard mixer) as the signal is sent to main mixer; between a DAT's output and an analog cassette input. When using a chain of processors, the 266xs may be placed either before or after effects or dynamics processors. We recommend you use common sense and experiment with different setups to see which one provides the best results for your needs.

Connect the AC power cord (shipped with the unit) to the 266xs rear panel POWER connector and an appropriate AC power source to turn the unit ON.

Section 4 - Technical Support and Facts

4.1 Technical Support

The 266xs is an all-solid-state product with components chosen for high performance and excellent reliability. Each 266xs is tested, burned-in and calibrated at the factory and should require no internal adjustment of any type throughout the life of the unit. We recommend that your 266xs be returned to the factory only after referring to the manual and consulting with dbx Customer Service.

Our phone number, Fax number and address are listed on the back cover of this manual.

When you contact dbx Customer Service, be prepared to accurately describe the problem. Know the serial number of your unit. This is printed on a sticker attached to the side panel of the unit.

NOTE: Please refer to the terms of your Limited Two-Year Standard Warranty, which extends to the first end user. After the warranty expires, a reasonable charge will be made for parts, labor, and packing if you choose to use the factory service facility. In all cases, you are responsible for shipping charges to the factory. dbx will pay return shipping if the unit is still under warranty.

Shipping Instructions: Use the original packing material if it is available. Mark the package with the name of the shipper, and with these words in red: DELICATE INSTRUMENT, FRAGILE! Insure the package properly. Ship prepaid, not collect. Do not ship parcel post.

4.2 Registration Card and User Feedback

We appreciate your feedback. After you have an opportunity to use your new 266xs, please complete the Registration Card and return it.

Section A - Appendix

A.1 Technical Specifications

Note: 0dBu = 0.775VRMS

Specifications are subject to change

INPUT (Balanced or Unbalanced):Impedance: > 40k Ω
Max Level: +22dBu**OUTPUT (Impedance Balanced):**Impedance: +4dBu: Balanced: 100 Ω
Unbalanced: 50 Ω
-10dBu: Balanced: 1k Ω
Unbalanced: 500 Ω
Max Level: > +21dBu, > +18dBm (into 600 Ω)**SIDCHAIN INSERT:**Input Impedance: >10k Ω
Output Impedance: 2k Ω
Max Input Level: +22dBu
Max Output Level: >+20dBu**FREQUENCY RESPONSE:**Flat: 20Hz - 20kHz, +0, -0.5dB
Bandwidth: 0.35Hz - 90kHz, +0, -3dB**SYSTEM PERFORMANCE:**Distortion + Noise: <0.2%; any amount of compression at 1kHz
Intermodulation Distortion: <0.2% SMPTE
Noise: <-93dB, unweighted (22kHz measurement bandwidth)
Dynamic Range: >114dB, unweighted
Interchannel Crosstalk: <-95dB, 20Hz to 20kHz
Common Mode Rejection: >40dB, typically >55dB @ 1kHz
Stereo Coupling: True RMS Power Summing™**THRESHOLD:**Compressor: OverEasy® or hard-knee; -40dBu to +20dBu
Expander/Gate: -60dBu to +10dBu**RATIO:**Compressor: 1:1 to Infinity:1
Expander/Gate: 1:1 to 4:1**ATTACK Time:**Compressor: Scalable Program-Dependent AutoDynamic™
Expander/Gate: <100 μ Sec**RELEASE Time:**Compressor: Scalable Program-Dependent AutoDynamic™
Expander/Gate: Program-Dependent**POWER SUPPLY:**Operating Voltage: 100VAC -120VAC 50/60Hz; 230VAC 50/60Hz
Power Consumption: 15 Watts
Operating Temperature: 32°F to 113°F (0°C to 45°C)**PHYSICAL:**Net Weight: 4.84 lbs (2.19kg)
Shipping Weight: 6.6 lbs (2.99kg)
Dimensions: 1.75" (4.4cm) H x 5.75" (14.6cm) D x 19" (48.26cm) W

A.2 Block Diagram

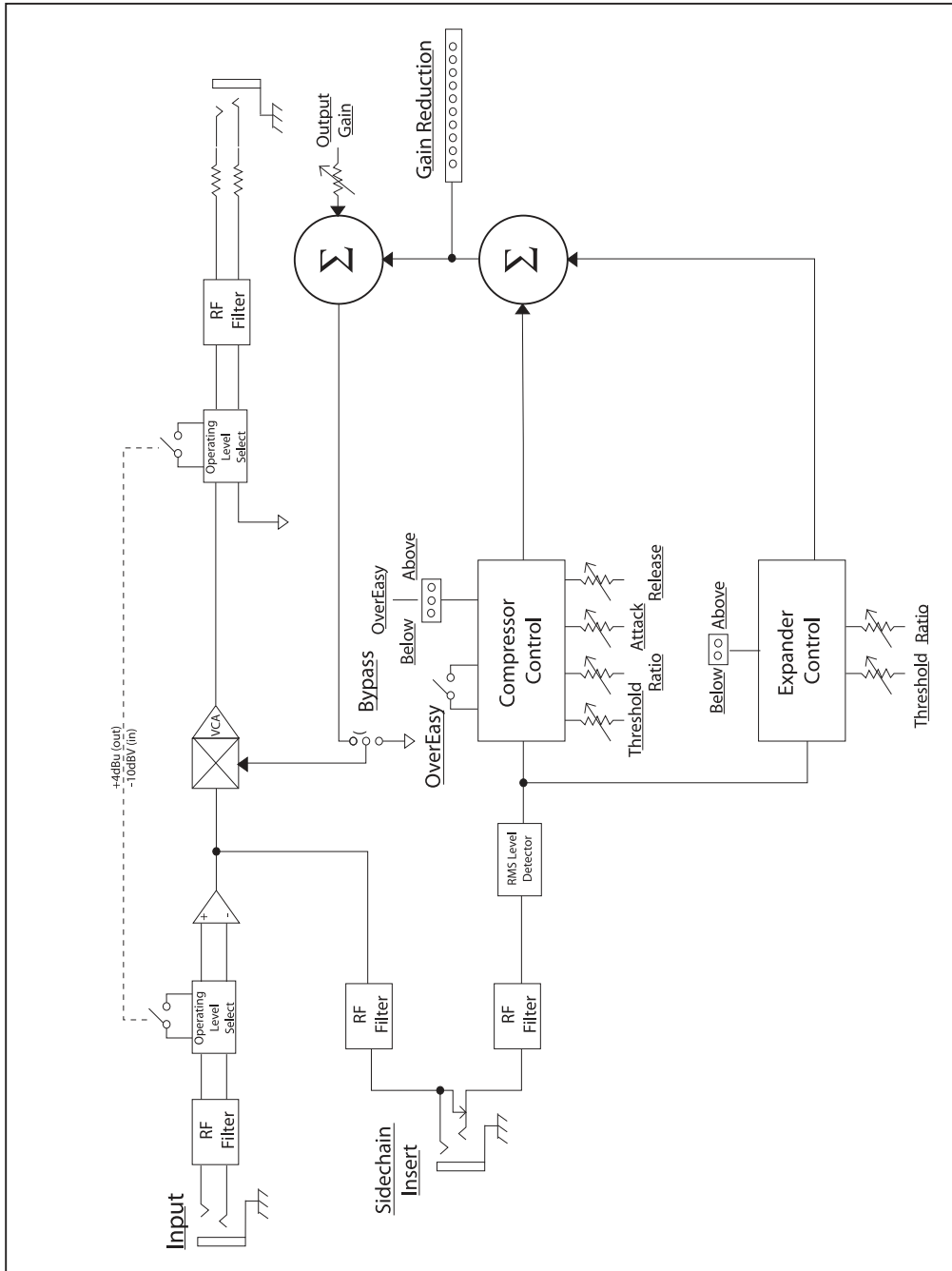



8760 South Sandy Parkway • Sandy, Utah 84070

Phone: (801) 568-7660 • Fax (801) 568-7662

Int'l Fax: (801) 568-7583

Questions or comments?

Contact us at www.dbxpro.com

Printed in China